



F99

**EXTERNAL WIGWAG
CONTROL MODULE**

Specifications

Dimensions:	4.9"L x 1.61"W x 0.81"H
LEDs:	NA
Voltage:	9 - 14V DC
Current:	limit of 2 Amps
Connector:	4.25" Unsheathed Pigtail
Wire colors:	Red: 12V DC Power Black: Ground Black/White Stripe: Output Yellow: +12V (driver side) Green: +12V (passenger side)

Technical Features

- External WigWag module allows you to control non-flashing lights
- Great for use with garbage/refuse trucks, work trucks and more
- Current limit of 2 Amps

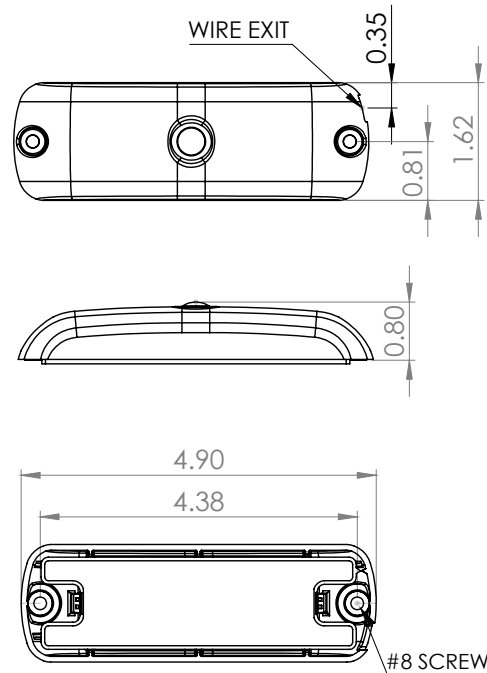

California Proposition 65

WARNING: This product can expose you to chemicals including lead, which is known to the State of California to cause cancer, birth defects or other reproductive harm

Part Numbers	Description	Std Pk	Connector
F99-XB00-1	External WigWag Control Module	TBD	4.5" Pigtail

