

The **TecNiq P11** was built for the demanding task of illumination in the most extreme conditions. Comprised of anodized aluminum, impact resistant polycarbonate, 100% waterproof and vibration resistant - the **P11** is a work horse. Proven performance with TecNiq proprietary thermal management testing and IP68 rated. Our flush mount work light beats the competition in quality and performance.



P11

**SURFACE MOUNTED
SPREADER LIGHT**

Technical features

- ✦ Vibration resistant and 100% water proof
- ✦ Reliable performance over 50,000 hours
- ✦ Proprietary thermal management provides powerful performance in a small package
- ✦ Designed for the most demanding task illumination applications, in the most extreme environments

Specifications

Dimensions:	4.81" x 1.61" x 2.04"
LEDs:	4 (white), or 2 + 2 red (red option)
Voltage:	9 - 30VDC
Current:	1.6A / 0.8A (White) 0.8A +0.3A(red) / 0.4A +0.15A(red)
Connector:	9" Pigtail
Mounting:	Mounts with 5/8" mounting bolt and hardware (included)
Lumens:	1450 Lumens, 825 Lumens +160 (red combo)

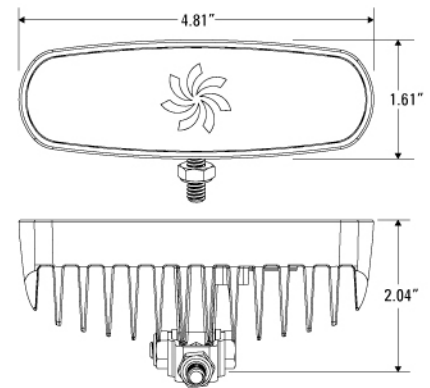

California Proposition 65

WARNING: This product can expose you to chemicals including lead, which is known to the State of California to cause cancer, birth defects or other reproductive harm

Part Numbers	Description	Std	Connector
P11-WRFP-1	Spreader Light, White & Red LED, Surface Mount, White Finish, Pigtail Wires	2	Sheathed Pigtail 9"
P11-WWFP-1	Spreader Light, White LED, Surface Mount, White Finish, Pigtail Wires	2	Sheatehd Pigtail 9"

