



E110 - 360° ULTRA SPOTLIGHT

THE E110 360° ULTRA SPOTLIGHT - REMOTE CONTROLLED HIGH POWERED ILLUMINATION

Introducing TecNiq's ALL NEW **E110 360° ULTRA SPOTLIGHT**. The E110 was built to provide remote accessible, high powered illumination (5000 lumens). Whether you are servicing utility lines, removing debris from storms, or simply working in poorly lit areas - the E110 has the light and features today's fleets and service vehicles demand.



Technical Features

- ☞ Surface mount design with mounting plate
- ☞ Comes with remote allowing for 360° of turn
- ☞ 100% sealed design keeps circuit boards safe
- ☞ Meets IP68 rating for dust and water incursion
- ☞ Backed by TecNiq's industry leading Lifetime Warranty

**For more information, contact a TecNiq Business Development Rep at
269-629-4440 or Sales@TecNiqInc.com**



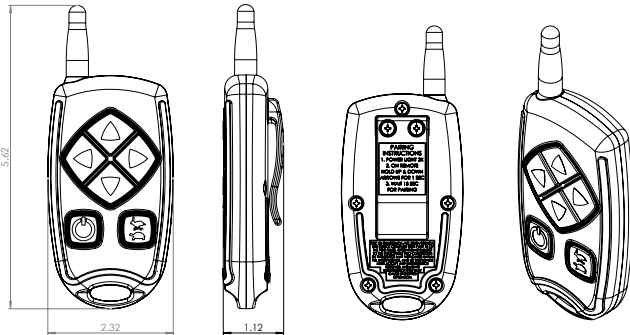
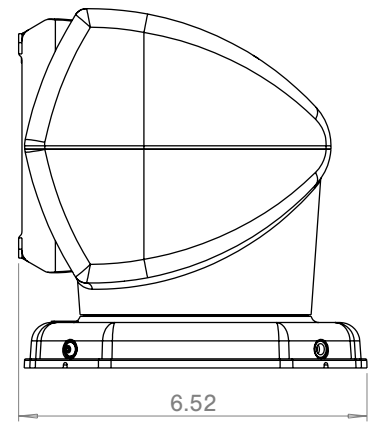
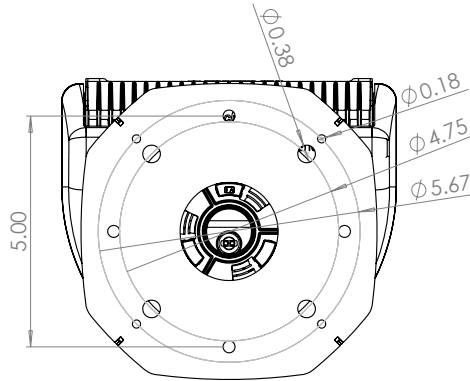
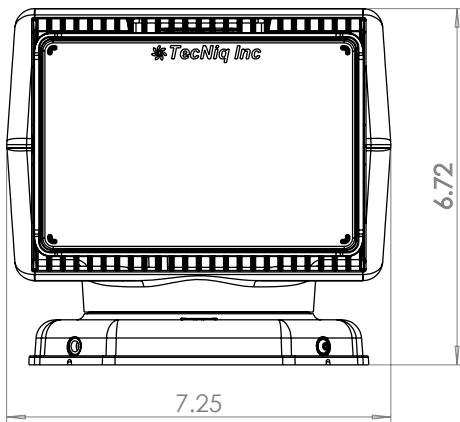

Specifications

Dimensions:	6.52" x 7.25" x 6.75"
LEDs:	10
Voltage:	10 - 26V DC
Lumens:	5000
Current:	12V@ 4A ±0.4A or 24V@ 2A ±0.2A
Connector:	12" Pigtail
Mounting:	Surface Mount w/Provided Mounting Plate
LED colors:	White

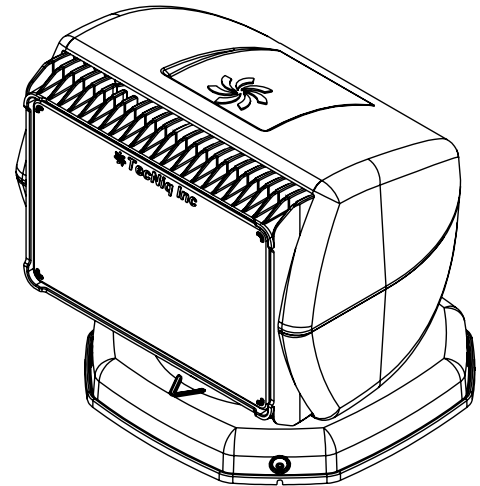

California Proposition 65

WARNING: This product can expose you to chemicals including lead, which is known to the State of California to cause cancer, birth defects or other reproductive harm

Part Numbers	Description	Std Pk	Connector
E110-WWG0-1	10 LED 360° Ultra Spotlight with Remote	-	12" Pigtail
E110-0GRC0-1	E110 Remote Control (CR2032 battery included)	-	-

